

USA general guidelines only. Each event has their own rules & regulations that may vary.

Perimeter Wall Exhibit

Definition: Standard booth located on the outer perimeter wall of the exhibit floor.

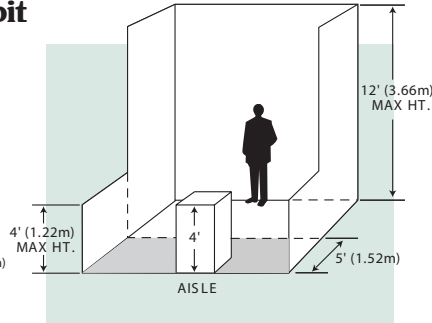
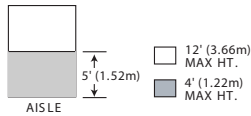

Island Booth

Definition: Exhibit with aisles on four sides.

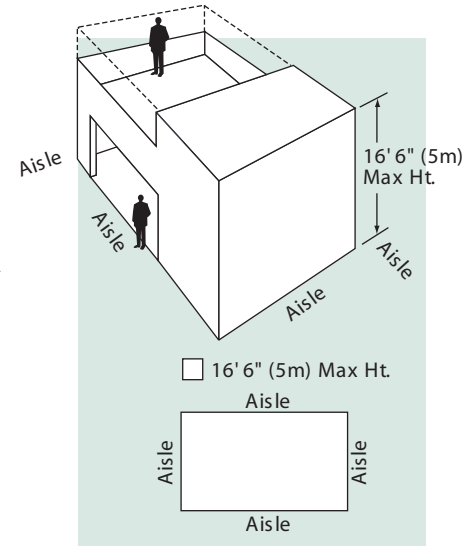

Canopies and Ceilings

Definition: An exhibit component supported over an exhibitor's space for decorative purposes only.

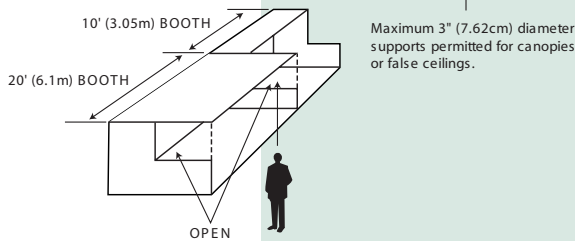
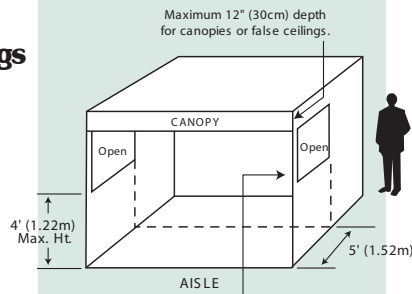

Hanging Signs

Definition: An exhibit component suspended above an exhibit of four or more standard units back-to-back with an aisle on at least three sides, for the purpose of displaying graphics or identification.

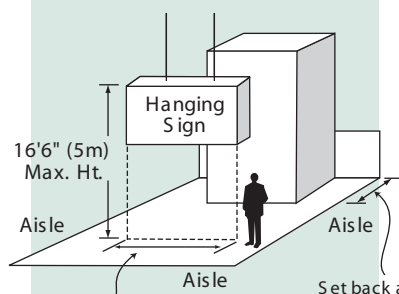

Length of sign not to exceed 50% of the corresponding dimension of the booth.

Set back at least 25% of the booth's width dimension from the back line of the booth.

Peninsula Exhibit

Definition: Exhibit with one or more display levels in four or more standard units back-to-back with an aisle on three sides.

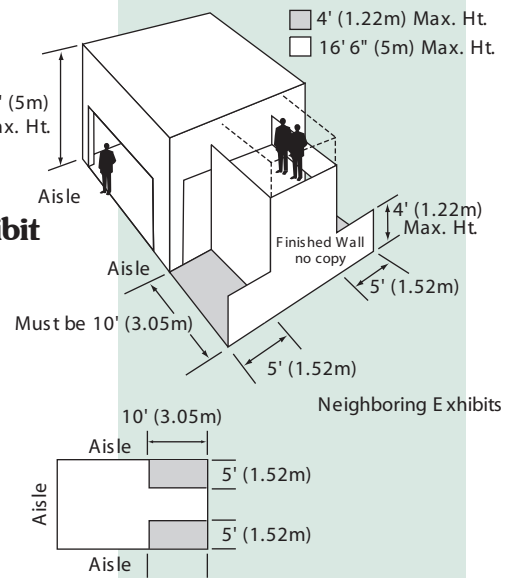

Standard Exhibit

Definition: One or more standard units in a straight line (minimum booth size is 10' x 10' = 100 sq.ft.)

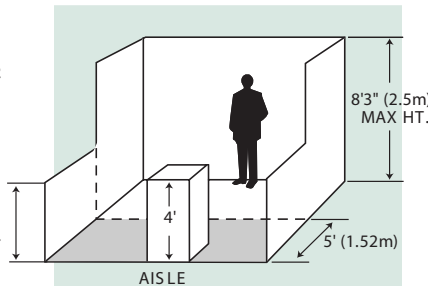

Demonstrating/Sampling

The part of the exhibit program involving the interaction of exhibit personnel and their audience through corporate presentations, product demonstrations or sampling.

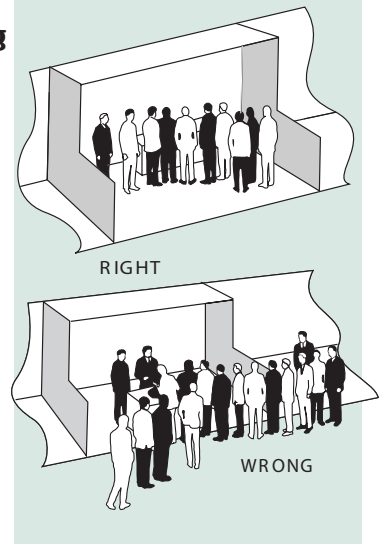

Display fixtures over 4' (1.22 m) high must be confined to that area of the booth that is at least 5' (1.52 m) from the aisle line.

